

Recommended Four Year Civil Engineering BS Program***

University of Nevada Reno 2008 - 2009 Catalog

Name: _____

Date: _____

Emphasis: _____

Yr. Sem Crs

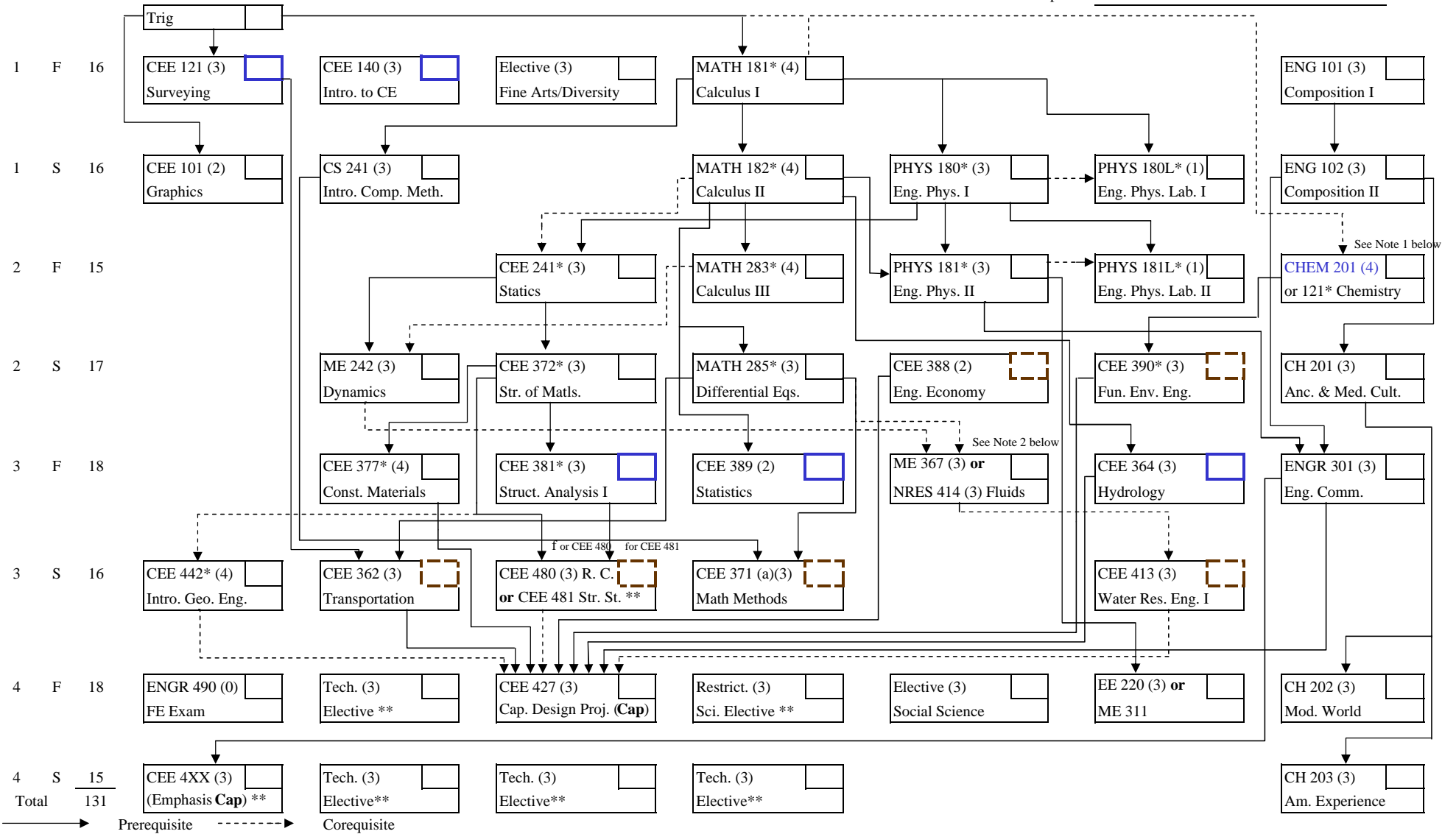

* Courses requiring at least a C (2.0 pt).

** See list of approved technical and restricted science electives. Total number of unique credits is 18 for the Second Capstone plus technical electives including CEE 480 and/or CEE 481.

*** A separate program for Environmental Engineering is available

(b) See Environmental Emphasis All students shall satisfy the core.

All students graduating under this catalog shall satisfy the 3 Cr. diversity requirement. A course could satisfy both social science and diversity or fine arts and diversity. If a student does not take a course that satisfies both, a 3 Cr. diversity course must be taken. The University course schedule provides a list of diversity courses

Note 1: MATH 181 is a prerequisite or corequisite for CHEM 201 and MATH 128 is a prerequisite or corequisite to CHEM 121

Note 2: The prerequisites for NRES 414 are PHYS 180 and MATH 182.